

# 49'W x 115' L x 24' H (15 m x 35 m x 7.3 m) CRESTLINE DOUBLE TRUSS ARCH SHELTER, VERTICAL SIDE PRODUCT MANUAL

ver.20170611



Read this manual before using this product. Failure to do so can result in serious injury.  
**SAVE THIS MANUAL**



## NOTICE

The warnings, cautions, and instructions discussed in this instruction manual cannot cover all possible conditions and situations that may occur. It must be understood by the user that common sense and caution are factors which cannot be built into this product, but must be supplied by the installer and/or user.

Tent, canopy, structure, and shelter products are manufactured for use as temporary structures and do not meet structural code unless specified. Since weather is unpredictable, the installer/end user must incorporate their own good judgment, common sense and knowledge of local conditions with the installation instruction guidelines. The installer is responsible for anticipating weather severity for proper time and method of installation.

## WARNING SYMBOLS AND DEFINITIONS

|                 |  |
|-----------------|--|
|                 | This is the safety alert symbol. It is used to alert you to potential personal injury hazards. Obey all safety messages that follow this symbol to avoid possible injury or death. |
| <b>▲WARNING</b> | Indicates a hazardous situation which, if not avoided, could result in death or serious injury.  |
| <b>▲CAUTION</b> | Indicates a hazardous situation which, if not avoided, could result in minor or moderate injury.   |

**Description**



**Crestline Truss Arch Shelter**

Fabric shelter constructed of arched metal beams that support the roof fabric. Truss Arches can be constructed using single arch or double arch designs. Shelter walls can be constructed using vertical or arched designs. Truss arch shelters may also be referred to as hoop buildings or Quonset huts.

**Suggested Equipment**

Drop cloth, ladder/ lift

**Crestline Truss Arch Shelter Specifications**

|                            |  |
|----------------------------|--|
| Width                      | 49 ft. / 15m                               |
| Length                     | 115 ft. / 35m                              |
| Area                       | 5635 ft <sup>2</sup> / 523.5m <sup>2</sup> |
| Overall Height             | 23.6 ft / 7.2m                             |
| Pitch                      | 9.8 ft / 3m                                |
| Complete Weight            | 16,090 Lbs. / 7298 Kg.                     |
| Series / Brand             | Crestline                                  |
| Class                      | Truss Arch Shelter                         |
| Center Pole                | No   |
| Style / Shape              | Frame                                      |
| Expandable                 | No   |
| Custom Printing Available  | No   |
| Fabric Material            | PVC Coated Polyester                       |
| Fabric Material Weight     | 18 oz. / yd <sup>2</sup> / 510.3 gsm       |
| Fabric Translucency        | Translucent                                |
| Water Repellency           | Waterproof                                 |
| Flame Resistant            | Yes  |
| UV Resistant               | Yes  |
| Mold and Mildew Resistant  | Yes  |
| Frame / Pole Material      | Galvanized / 60mm                          |
| Persons required for setup | 6-10                                       |

**SAFETY**

**INSTALLATION**

**MAINTENANCE**

**CONTACTS**

## PERSONAL SAFETY



**STAY ALERT:** Watch what you are doing, and use common sense when installing/striking a tent, canopy, structure, or shelter. Do not setup/strike while under the influence of drugs, alcohol, or medication. A moment of inattention may result in serious personal injury.



**DO NOT OVER LIFT:** The equipment may be heavy and may require 2 or more people to lift and move.



**DO NOT OVERREACH:** Keep proper footing and balance at all times. Use a ladder when necessary.



**DRESS PROPERLY:** Do not wear loose clothing or jewelry. Contain long hair. Keep hair, clothing, and hands/gloves away from power equipment and snag or pinch points.



**USE SAFETY EQUIPMENT:** Eye protection, safety shoes, hard hats, or hearing protection must be used for appropriate conditions.

## WEATHER

Since weather is unpredictable, the installer/end user must incorporate their own judgment, common sense and knowledge of local conditions with the installation instruction guidelines. The installer is responsible for anticipating weather severity for proper time and method of installation.

- **Rain:** **⚠️WARNING** Rain water can collect on the tent fabric and cause 'ponding' or 'water pocketing' under certain weather conditions, especially if the tent is not installed and tensioned correctly. The additional weight from the water will cause the tent to sag and ponding will continue to get worse. The weight can destroy the tent fabric and/or cause the poles and baseplates to sink into the soil. Highly saturated soil will cause the stakes to lose their holding power.
- **Wind:** **⚠️WARNING** Wind or wind and rain can cause the tension of the tent to change by loosening ratchet assemblies, pulling stakes, and or causing the poles to shift or sink. It is very important to do routine maintenance checks and maintain proper tension on the tent top at all times especially if weather conditions are such that ratchets are beginning to loosen.
- **Lightning:** **⚠️WARNING** Immediately evacuate the tent until the chance of a lightning strike is no longer present.
- **Snow:** Tents, canopies, structures, and shelters are not designed to carry any type of snow loading. These products should not be used if snow of any kind is present, and must be evacuated immediately.

## SITE SELECTION

Site selection is extremely important. The installer must adhere to local building codes and fire regulations. The installer must evaluate each installation site and determine the proper securing and anchoring method and device appropriate for the conditions. Some soils require different staking or securing methods than what may be/have been purchased with the standard tent package. Celina Tent's instructions, YouTube videos, and Layout Handbook summarize all the functions of each product, the rules for using them and suggestions for their use. However, field situations, site conditions, weather and local experience may mandate other methods. Review the following conditions at the proposed site and plan accordingly.

The best site qualities are:

- **Location:** Elevated, level, and clear of debris
- **Soil Conditions:** Adequate for stable anchoring
- **Space:** Adequate space for the perimeter and stake lines
- **Surface Type:** Grass, Gravel, Concrete, Asphalt, Wood
- **Site Access:** Materials and services can easily be delivered to the site

**⚠️WARNING** Also allow for:

- **Overhead Obstructions:** Electrical/telephone lines, tree branches
- **Underground Utilities:** Electric, Gas, Oil, Steam, Telephone, CATV, Water, Sewer
- **Weather Effects:** Monitor for extreme weather conditions and evacuate if necessary
- **Emergency Exit Capabilities:** Provide evacuation routes in case of a fire or bad weather

## Before You Stake

By law you are required to contact your local “Call before you dig” number before you plan to dig or drive tent stakes / anchors. After calling, your local utility companies will mark the location of all underground utility lines. Laws from state to state vary on how far in advance you must call. Planning ahead and checking with your state’s program is always a smart idea. Failure to obtain a utility line location before digging can result in a substantial fine or serious injury. Please find your local “call before your dig number” in the contacts section of this manual.

**▲WARNING** Prior to staking, be sure that no underground utilities are present. Celina is not responsible for methods that installers may choose to erect and secure the tent, canopy, structure, or shelter to the site surface. Celina’s responsibility is limited to the manufacture of the tent parts and materials. It is the installer’s responsibility, not Celina’s, to determine the appropriate number of stakes to meet the necessary wind loads on the installation site.

**▲WARNING** Soil and setup conditions can vary greatly between installation sites. It is the installer’s responsibility to be sure the staking is adequate for each site on each setup. Additional staking, tiebacks, and/or stake bars may be required in order to safely setup and secure the product.

**▲WARNING** The number of stakes suggested in this manual routinely does not meet the relevant local codes of the installation site. The number of stakes included in the standard kit will, in most cases, keep the tent, canopy, structure, or shelter setup. Due to various soil conditions the standard staking kit may be inadequate to keep the tent secure in high winds and wet or threatening weather. Regardless of the number of stakes included in standard kits, Celina makes no representation or warranty as to whether this is sufficient to meet the requirements for your installation site(s).

## NOTE

**Attention:** Required hardware having a suffix of A, B, C, D, R or L indicate similar in make but are modified slightly for specific locations. It is typically on the end walls or corners where a component will a suffix A, B, C, D, R or L are located. Be sure not to mix these parts with the components without the suffix letters.

# REQUIRED HARDWARE

## 49'(15m)W x 115'(35m)L x 24'(7.3m)H Crestline Truss Arch Shelter

| Part Code | Description  | Qty. |
|-----------|--|------|
| 1         | Top roof tube  | 17   |
| 1A        | Top roof tube in the front and back panel                  | 2    |
| 2         | Upper Roof curving tube                                    | 34   |
| 2A        | Upper Roof curving tube in the front panel                 | 2    |
| 2B        | Upper Roof curving tube in the back panel                  | 2    |
| 3         | Lower roof curving tube                                    | 34   |
| 3A        | Lower roof curving tube at the front panel                 | 2    |
| 3B        | Lower roof curving tube at the back panel                  | 2    |
| 3C        | Roof curving tube at shoulder height                       | 34   |
| 3D        | Roof curving tube at shoulder height at the front panel    | 2    |
| 3E        | Roof curving tube at shoulder height at the back panel     | 2    |
| 4         | Sidewall tube  | 34   |
| 4A        | Sidewall tube in the front panel                           | 2    |
| 4B        | Sidewall tube in the back panel                            | 2    |
| 5         | Roof purlin and horizontal tube                            | 342  |
| 6L        | Base plate in corner                                       | 2    |
| 6R        | Base plate in corner                                       | 2    |
| 7         | Base plate for standing legs in the front and back panel   | 9    |
| 8         | Base plate for sidewall                                    | 34   |
| 9         | Lower section of standing legs in back panel               | 5    |
| 10        | Middle section of the middle standing legs in back panel   | 3    |
| 11        | Upper section of the outer standing legs in back panel     | 2    |
| 12        | Upper section of the inner standing legs in back panel     | 2    |
| 12A       | Upper section of the middle standing legs in back panel    | 1    |
| 13        | Middle rail of back panel                                  | 14   |
| 13A       | Upper side rail of back panel                              | 2    |
| 13B       | Lower side rail of back panel                              | 4    |
| 14        | Upper door track   | 2    |
| 14A       | Middle door track  | 2    |
| 14B       | Lower door track   | 1    |
| 14C       | Lower door track for winch rail                            | 1    |
| 15        | Upper standing leg in front panel                          | 2    |
| 15A       | Lower standing leg in front panel                          | 1    |
| 15B       | Lower standing leg in front panel for winch rail           | 1    |
| 16        | Rail of front panel (beside the door)                      | 8    |
| 16A       | Upper side rail of front panel                             | 2    |
| 16B       | Lower side rail of front panel                             | 6    |
| 16C       | Bottom rail for winch of mechanical door (beside the door) | 1    |
| 17        | Wind Brace Support   | 4    |
| 17A       | Tube clip for wind brace support                           | 8    |

SAFETY

INSTALLATION

MAINTENANCE

CONTACTS

# REQUIRED HARDWARE

## 49'(15m)W x 115'(35m)L x 24'(7.3m)H Crestline Truss Arch Shelter

| Part Code | Description  | Qty.    |
|-----------|--|---------|
| 18        | Inner cover tensioning tube of front cover                                   | 2       |
| 18A       | Outer cover tensioning tube of front cover                                   | 2       |
| 19        | Inner cover tensioning tube of back cover                                    | 4       |
| 19A       | Outer cover tensioning tube of back cover                                    | 2       |
| 20        | Cover Tensioning tube for roof cover   | 2 Sets  |
| 22        | Door dropping tube (swaged)  | 6       |
| 22A       | Door dropping tube   | 6       |
| 23        | Door dropping tube at the bottom (swaged)                                    | 1       |
| 23A       | Door dropping tube at the bottom   | 1       |
| 24        | Auger  | 38      |
| 24A       | Wrench for auger   | 1 Set   |
| 25        | Stake peg  | 94      |
| 28        | Hexagonal bolt M10x85MM  | 65      |
| 28A       | Carriage bolt M10x85MM   | 370     |
| 29        | Hexagonal bolt M10x75MM  | 830     |
| 30        | Hexagonal Bolt M10x30MM  | 35      |
| 31        | Bolt M8x15 for tie down ratchet  | 76      |
| 31A       | M5x10 Self-tapping screws for securing the door cover to the dropping tube   | 28      |
| 32        | Tie down ratchet   | 38      |
| 32A       | Band for tie down ratchet  | 38      |
| 34        | Roof cover   | 1       |
| 35        | Top cover above the door   | 1       |
| 36        | Side cover beside the door   | 2       |
| 37        | Door cover   | 1       |
| 38        | Back cover   | 1       |
| 39        | Rope for fastening the roof cover, the door cover and the front & back cover | 450m    |
| 40        | Plastic cap for tensioning tube  | 24      |
| 41        | Components for mechanical door   | 1 Set   |
| 42        | Turnbuckle and steel wire for the roof                                       | 48 Sets |
| 42A       | Turnbuckle and steel wire for the sides                                      | 36 Sets |
| 42B       | Turnbuckle and steel wire for the front & back panel                         | 10 Sets |
| 43        | Door beam  | 1 Set   |
| 43A       | Vertical support tube for door beam  | 1       |
| 44        | The fabric used for preventing the roof cover from abrasion (frame tape)     |         |

SAFETY

INSTALLATION

MAINTENANCE

CONTACTS

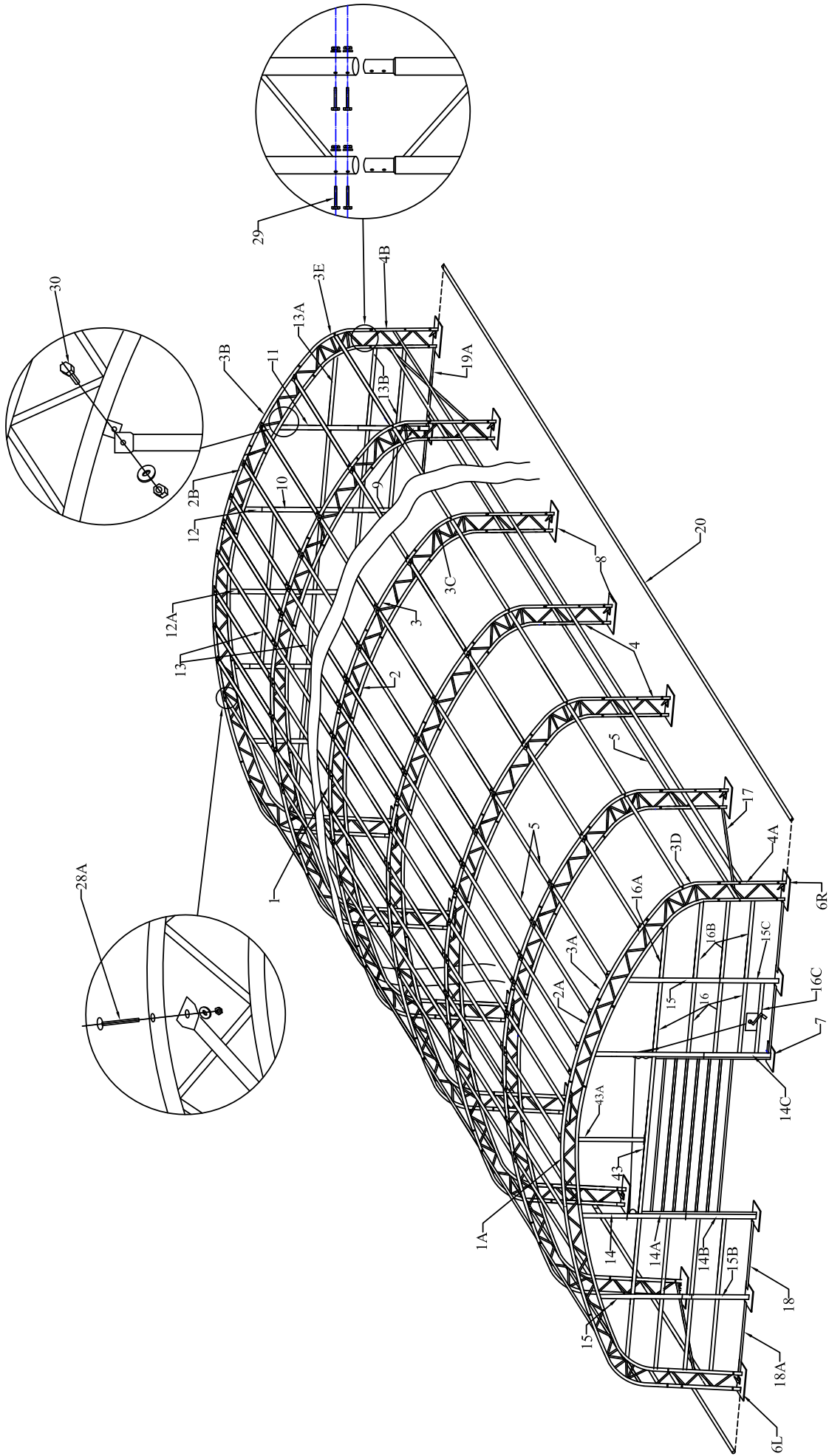

**Crestline double truss arch shelter 49'(15m)W x 115'(35m)L x 24'(7.3m)H**

Remove all the components from packaging to ensure all components are present by checking with the required hardware. \*\*The shelter must be secured to a firm surface that can receive and retain pegs firmly in position. The shelter should be installed on FIRM GROUND, not on SWAMP OR SOFT/ WET GROUND. The base flanges must be secured so they cannot be moved. \*\*

SAFETY

INSTALLATION

MAINTENANCE

CONTACTS

# PARTS / MINIMUM STAKING LAYOUT

## Position of Base Flanges

**Note:** Square your site with a string or chalk line prior to laying out the parts for installation. This makes preliminary work much easier on an open clean space rather than having parts scattered in the way. It is recommended that the string or chalk line is slightly larger than the tent so not to be in the way during installation. All base plates will sit inside the squared rectangular space.

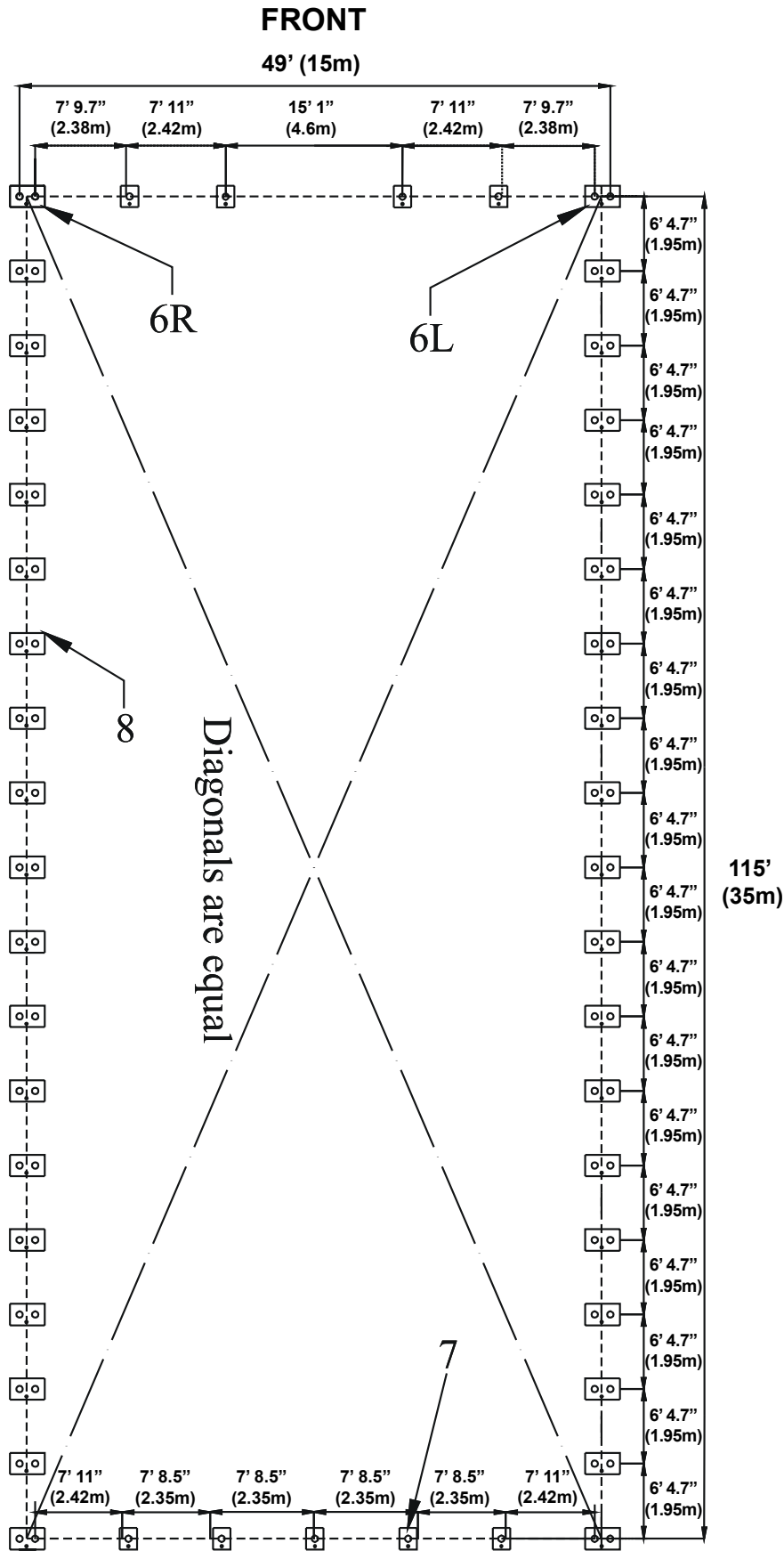

SAFETY

INSTALLATION

MAINTENANCE

CONTACTS



Arch Dimensions

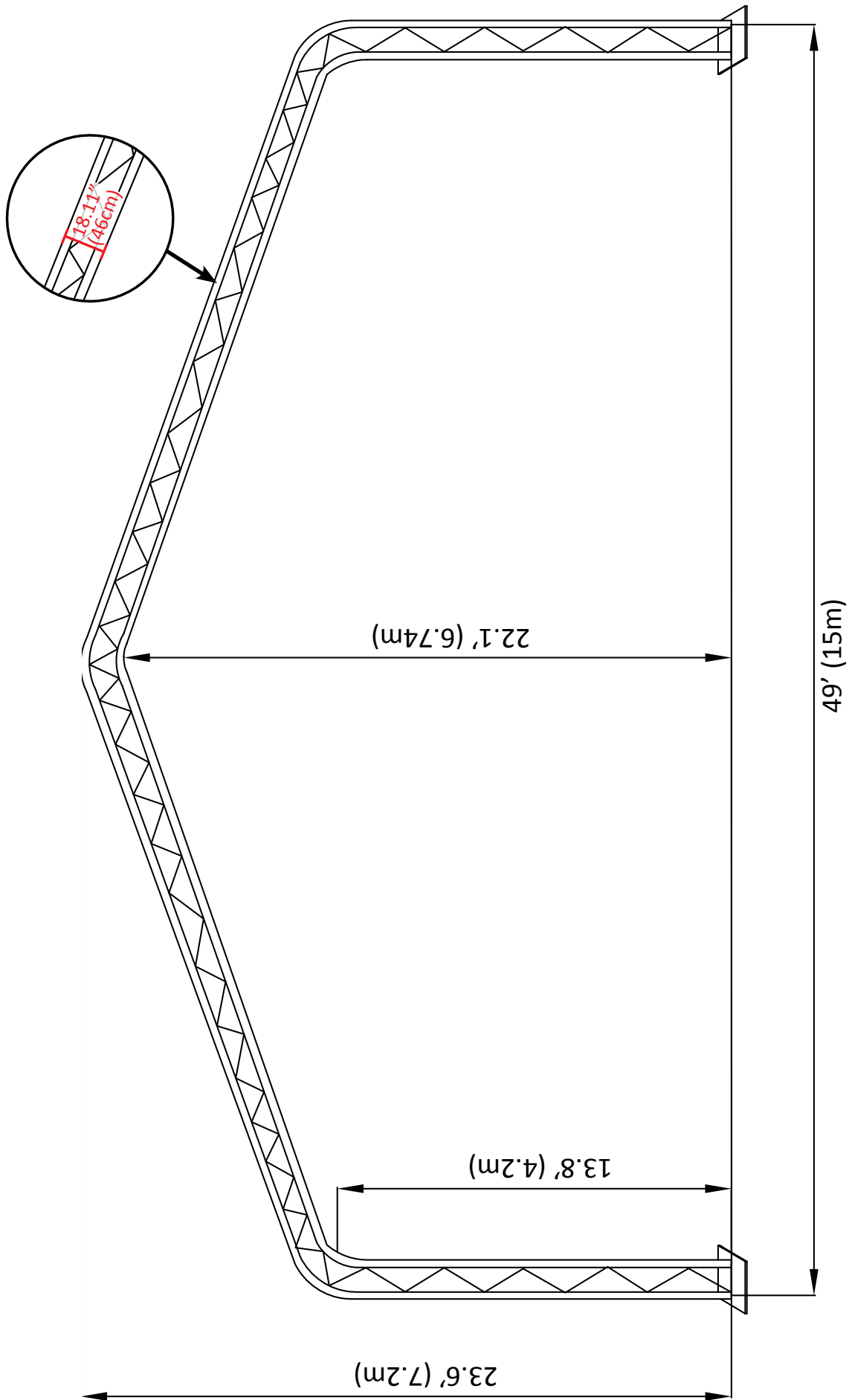

SAFETY

INSTALLATION

MAINTENANCE

CONTACTS

## Set Up Instructions

1. Layout the frame parts on the ground in the approximate location when they will be when the frame is assembled. (See parts / minimum staking layout diagram)



2. Bolt ratchets to base flanges: Attached one tie down ratchet (#32) to each base flange along the sidewall length of the structure. Use two bolts M8x15 (#31) for each ratchet to secure it to the base flange.



3. Arch Assembly: Assemble all the arches and lay them **ON THE GROUND** first. **DO NOT** erect the arches until all the arches are assembled. Connect the arches by using the hexagon bolts with washers and nuts (#29) through the pre-drilled holes in the frame members. **NOTE:** Please notice the part code of the arch sections. The sections of the middle, front, and back arches are not the same. Check with the parts list and diagram to ensure the correct parts and placement. Each arch consists of:

- a. One top roof tube (#1/1A)
- b. Two upper roof curving tubes (#2/2A/2B)
- c. Two lower roof curving tube (#3/3A/3B)
- d. Two roof curving tube at shoulder height (#3C/3D/3E)
- e. Two sidewall tube (#4/4A/4B)
- f. Two base plates (#6L/6R/8)



## Front Arch

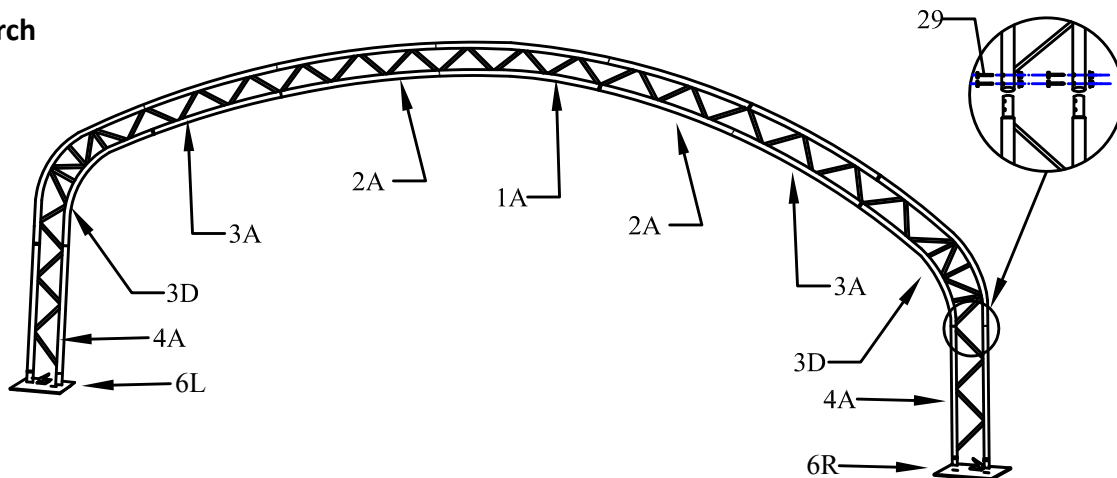

# INSTALLATION INSTRUCTIONS

## Middle Arch

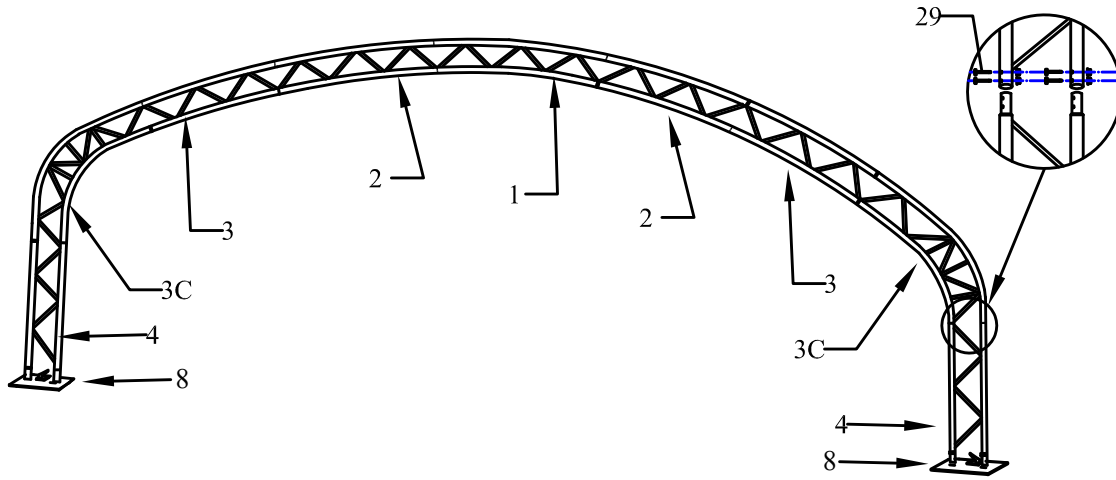

## Back Arch

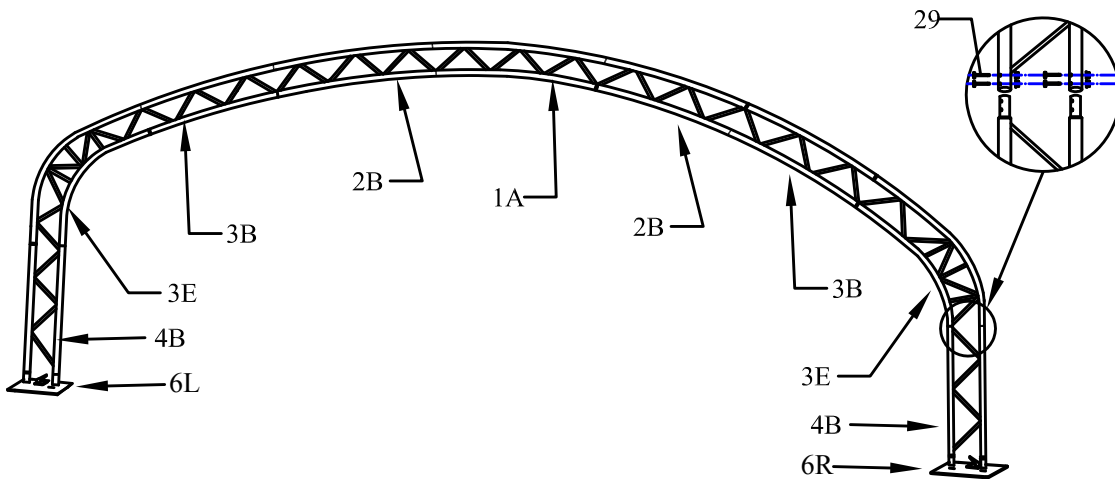

4. Erecting the arches: Erect the front arch by using ropes. Tie and secure the rope to a heavy object to secure the arch standing temporarily. Lift the arch and secure the base flanges.



SAFETY

INSTALLATION

MAINTENANCE

CONTACTS

5. Assembling the roof purlins: Immediately after erecting the first arch, erect the 2nd arch in the same way. Connect the two erected arches using the roof purlin and horizontal tubes (#5). Secure the roof purlin tube into place using carriage bolts and nuts (#28A).



6. Assembling the wind brace supports: Wrap the tube clip (#17A) around the interior arch. The tube clip is movable to ensure the proper position. Install the wind brace support (#17) that connects the front arch to the first interior arch. The wind braces give the arch assemblies strength as a unit. Use bolt M10x30 (#30) at the end of each wind brace support to secure.

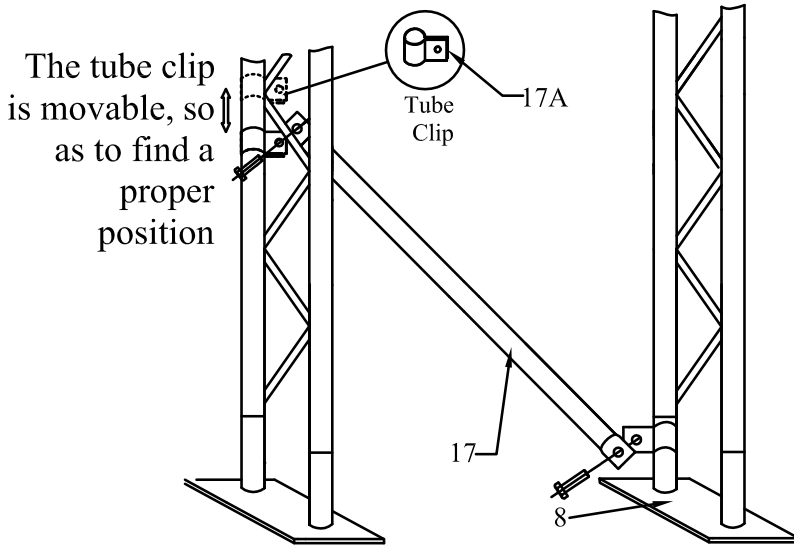

7. Install the other arch assemblies in the same manner. Overlap pinched ends of roof purlins onto same carriage bolts inside frame assembly.

8. Check entire frame assembly so it is square and plumb. Adjust wind braces and roof purlins as necessary to bring frame into plumb. Tighten frame bolts adequately.

9. Installing Concrete anchors (Optional staking method used. Concrete anchors not included but recommended): Measure to ensure the base flanges are square and the arches are plumb in all directions. Drill three holes in the concrete that align with the holes in the base flange. Hammer the anchor stud through the base flange and drilled hole leaving room at the top for the bolt. Place washer and bolt on the anchor stud and tighten, repeat at remaining holes.



Installation for earth anchors: Using one base flange as a panel, mark the earth auger hole through the base flange by pushing the auger point through the base flange hole in place. This will leave an impression in the ground when the base flange is removed. The auger tip should be started into the ground where the depression under the hole was made. After the hole is marked, move the base flanges to one side to expose the impression for the auger. Using a wrench (part #24A) turn the earth auger into the ground. Leave sufficient shaft above the ground to allow for the base flange thickness and adequate thread to be exposed for the washer and nut to be tightened over the base flange. Replace the base flange into place, with the threaded shaft of the auger sticking through the base hole. Re-check the dimension from the corner or adjacent base plate before tightening. Tighten the nut and your assembly will be securely fastened to the ground. Follow the staking layout for each base flange assembly. Alignment and dimensions should be checked continually as base plates are secured.

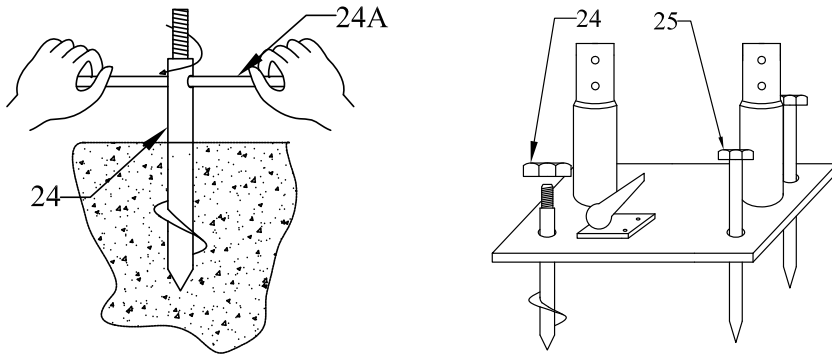

10. Installing wind stabilizers cables and turnbuckles: On each side of the frame, between the first and last two groups of arches, on each first and last arch of the roof, and on the front and back panel frame, cables with turnbuckles are provided to align and strengthen frame. After installing all cables with cable clamps, tighten the turnbuckles slightly to adjust the arches vertically and to add rigidity. See diagram on page 14 for wind stabilizer locations.



# INSTALLATION INSTRUCTIONS

Wind stabilizer locations:

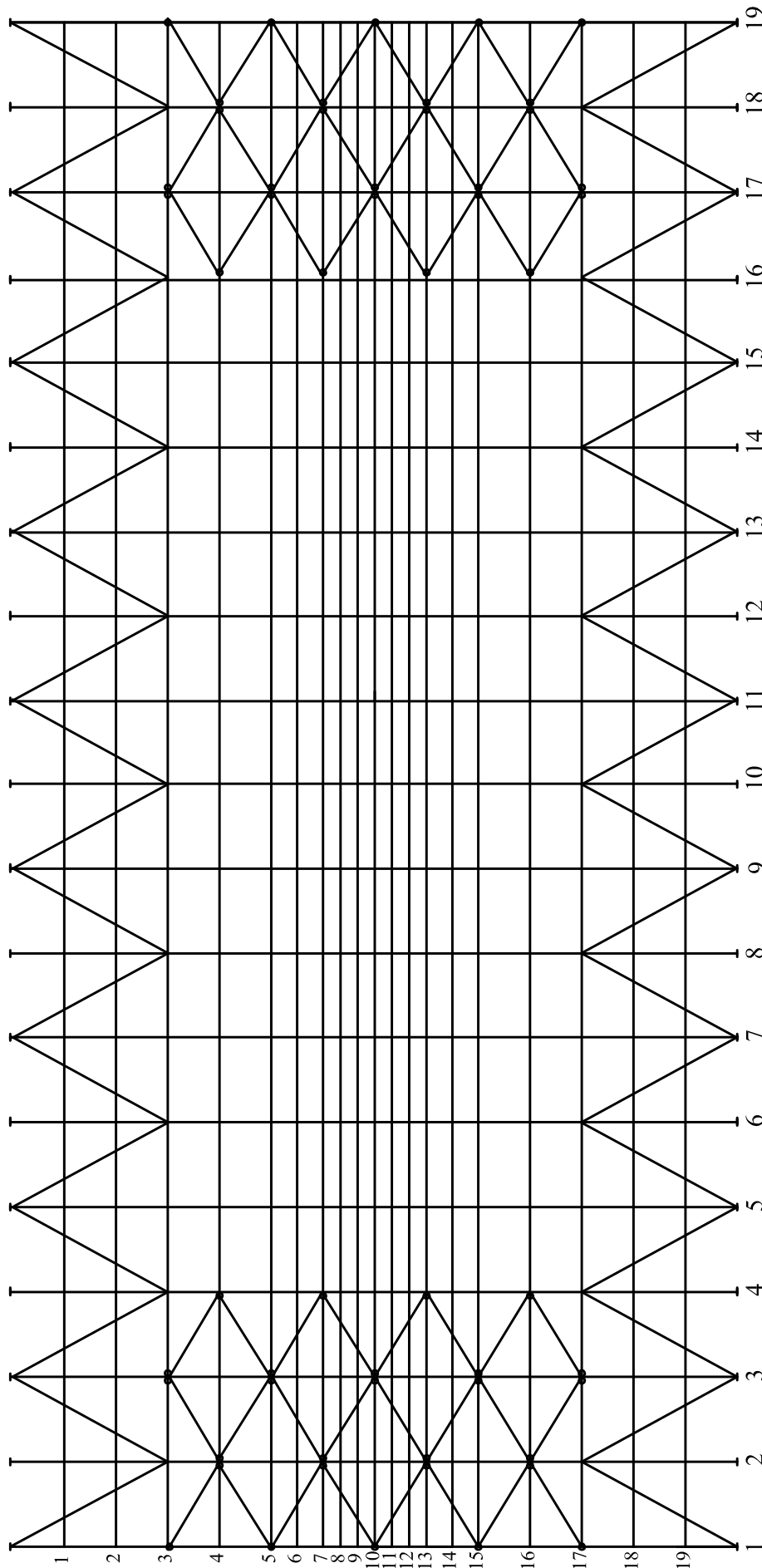

SAFETY

INSTALLATION

MAINTENANCE

CONTACTS

# INSTALLATION INSTRUCTIONS

11. Assemble the front arch frame work. Install remaining wind stabilizers cables and turnbuckles.



Front Arch Assembly

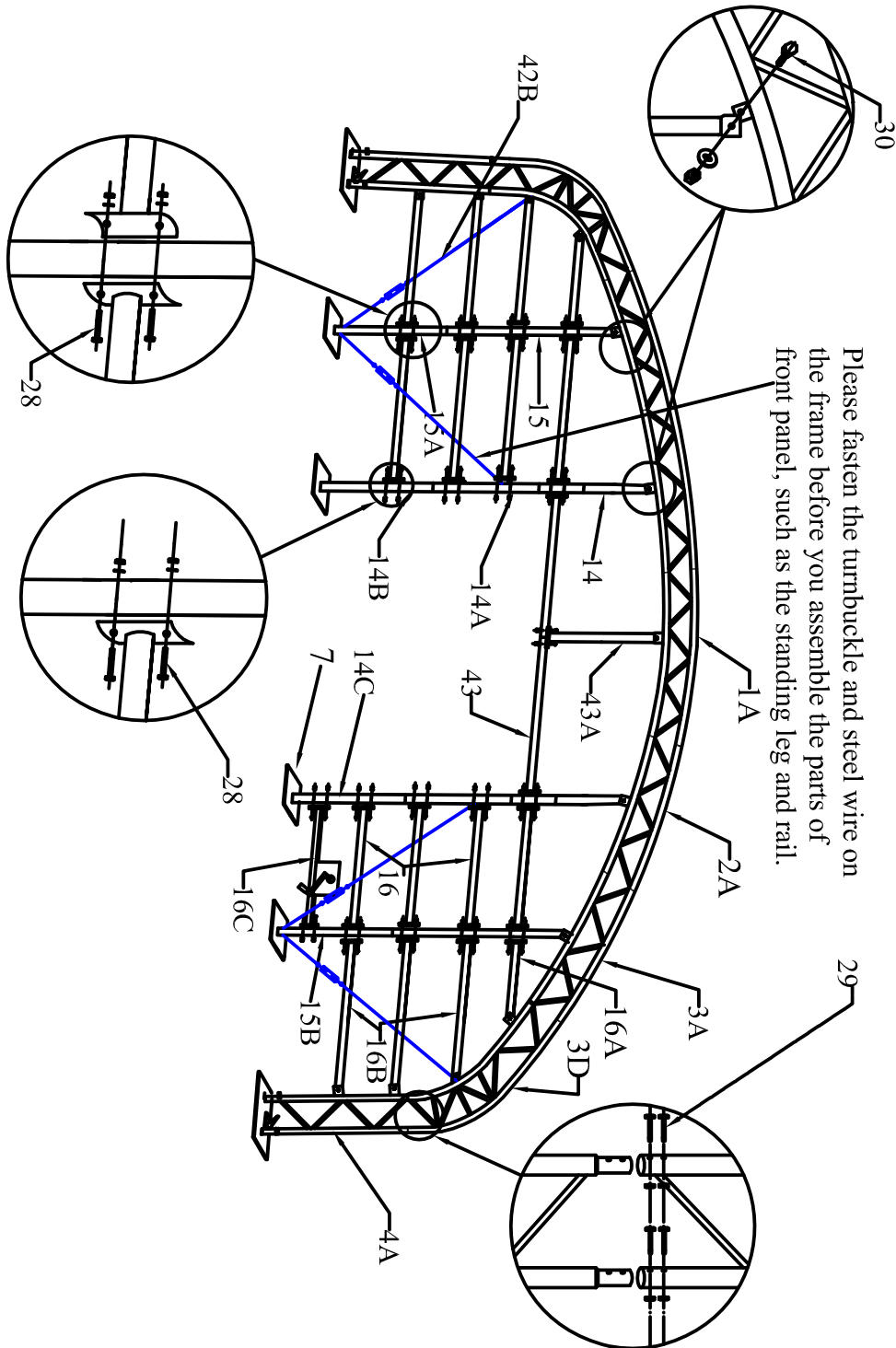

SAFETY

INSTALLATION

MAINTENANCE

CONTACTS

12. Assemble the back arch frame work. Install remaining wind stabilizers cables and turnbuckles.



Back Arch Assembly

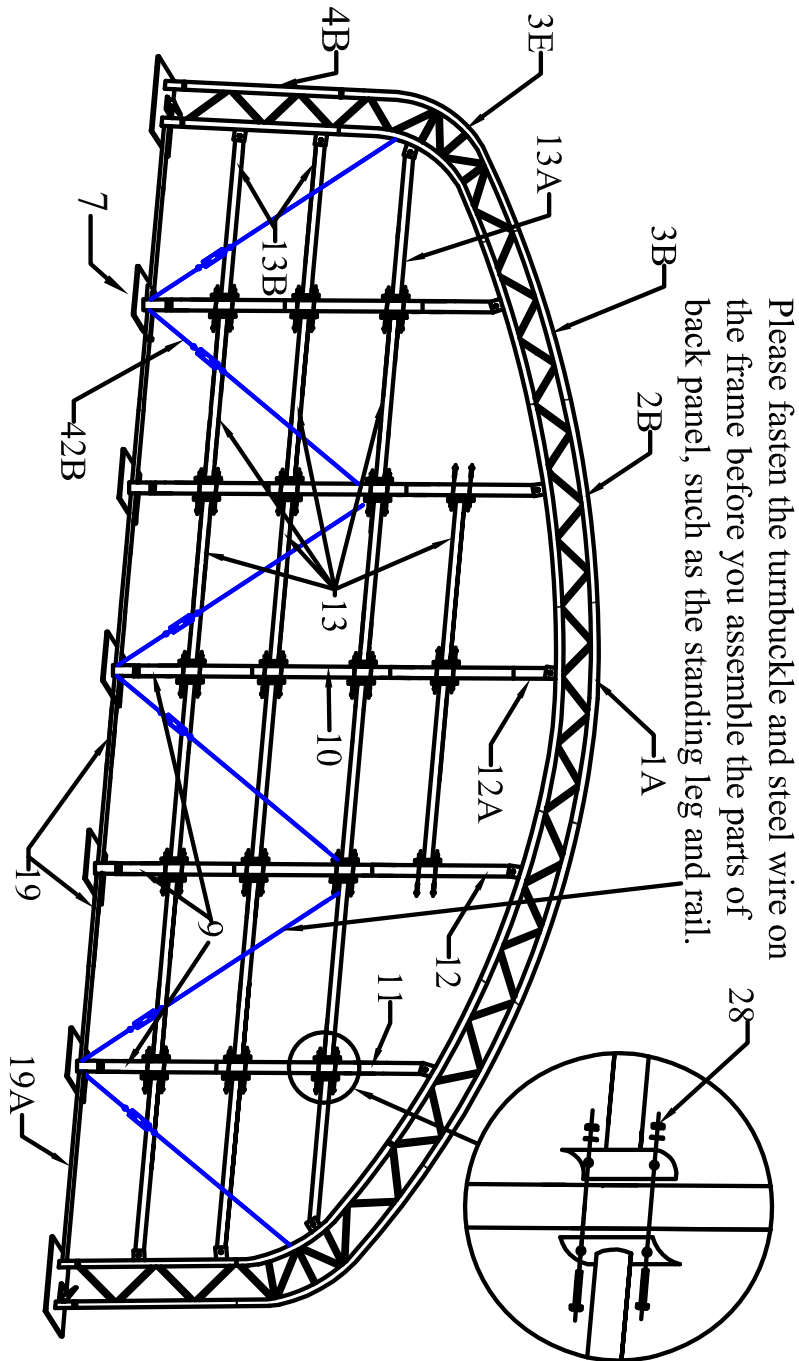



13. Roof Cover Installation: Unpack the cover and lay parallel to the frame on one side. The cover must be pulled over the top of the frame without being snagged or stressed on any parts of the frame. Insert the tensioning tube (#20) on one side, cut small slits in the pocket for attaching the rope to the tube. Use multiple ropes over the top of the frame as pictured. Have a person(s) inside the frame on a ladder / lift to assist in getting the roof cover over the frame. This will ensure the cover will go on without any damage.



14. Tighten the roof over the frame from front to back.

- a. The roof cover is tensioned from front to back by lacing it to grommet flaps inside the cover, inside the unit at both front and back arches.
- b. Using the ropes provided, lace the cover grommet flap around the main frame front and back arch pieces. Start in the middle of each arch and lace to each side. Adjust rope length by tying pieces together or cutting as necessary.
- c. Lace all grommets on the covers inside flap with rope. Starting in the middle top point over the door, tighten lacing only enough to take wrinkles out of the cover. Repeat for the back arch. **DO NOT** over tighten lacing to pull out grommets.
- d. After the roof cover lacing is adjusted evenly across the grommet flap, go back and re-adjust the rope. At this point, the main cover can be pulled taut enough to take all excess materials and wrinkles out of cover.
- e. Repeat these steps 2-3 weeks after assembly is complete and the roof cover has had a chance to stretch out over the frame completely.



# INSTALLATION INSTRUCTIONS

15. Fasten the roof cover (#34) by inserting the remaining tensioning tube (#20). Place a plastic cap (#40) on the ends of each tensioning tube.

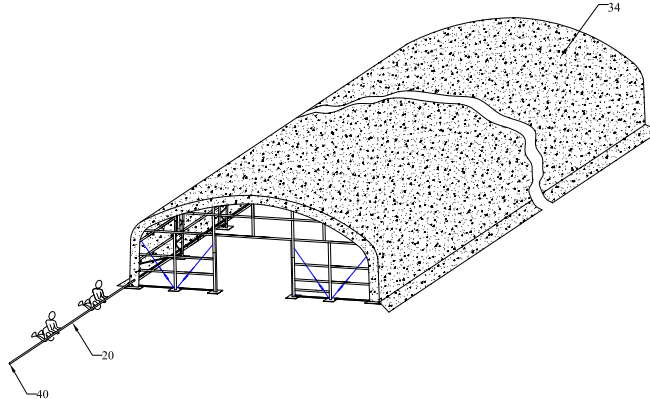

16. Make small cuts using a scissors in the roof cover pocket for the ratchet tie down strap to go through. Draw the outline of the cuts according to the position of the ratchet(#32). Cuts should be right upon the ratchets.

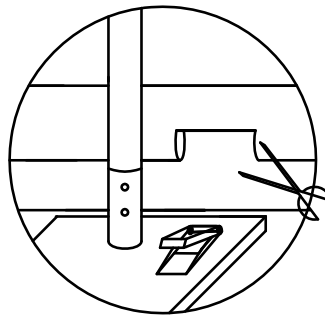
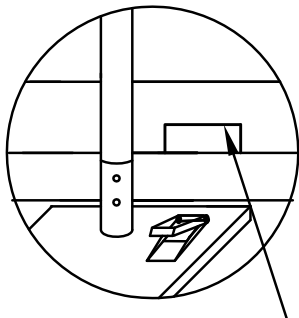

draw the outline of cuts

17. Loop the band for the tie down ratchet (#32A) around the tensioning tube through the cuts on the pocket of the roof cover. Bands do not attach to tensioning tube, but loop around and secure at both ends on the ratchet. Pull the bands through the reel of the ratchet and tension the band by the ratchet.

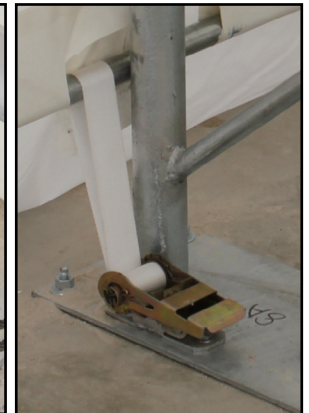
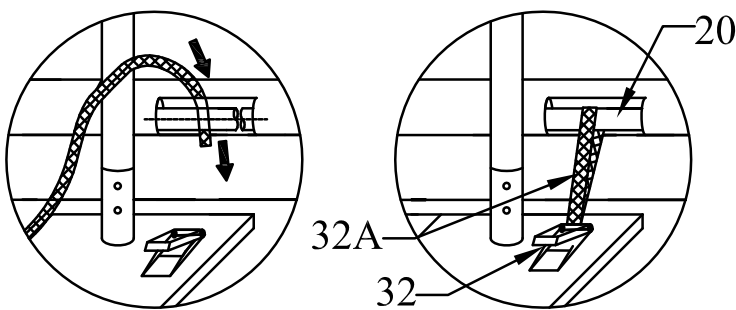

18. Tension the cover on the frame from side to side, taking up the slack in the tie bands by ratcheting the mechanisms, tightening cover. Evenly adjust ratchets on both sides of the roof to take out the wrinkles. **DO NOT FULLY TIGHTEN YET.** Leave adequate slack so that the cover can also be adjusted front to back in the next step.

## 19. Assemble the front and back cover.

- a. Secure front and back cover to the arch panels by using the ropes provided.
- b. Once both front and back covers are installed, the roof cover edge flap, front and rear, should be tightened and tied off. Begin by pulling the remaining roof cover over the frame arch, so the rope pocket is over the edge of the frame. Tie off the rope that goes through the rope pocket on one side. The rope ties off to the loops that are located on the base flange at each corner (6L or 6R). Moving to the other side, begin to pull the rope.
- c. Hold the rope in hand, and push down at the bottom of rope with a foot. Pull the rope tight, and tie off to the welded hoop on the base flange.
- d. As you are pulling the edge rope, it will be necessary to adjust the excess material that will collect along the rope. Adjust the material so that it is not bunched up and it does not pull the roof cover to one side or the other. Once the front is completed, repeat the process on the rear flap of the roof cover.



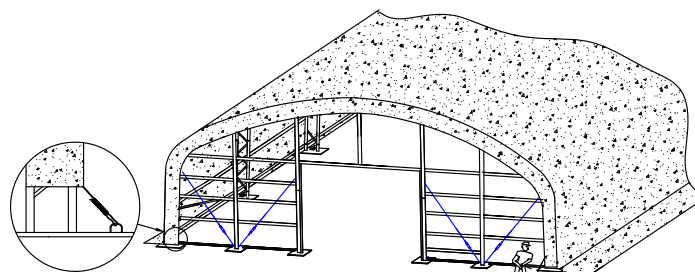

Fastening the two ends of the Roof Cover

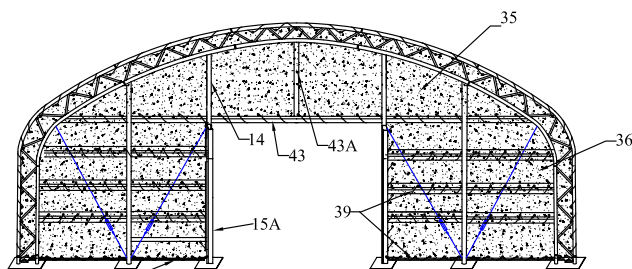

Installation of Front Panel Cover

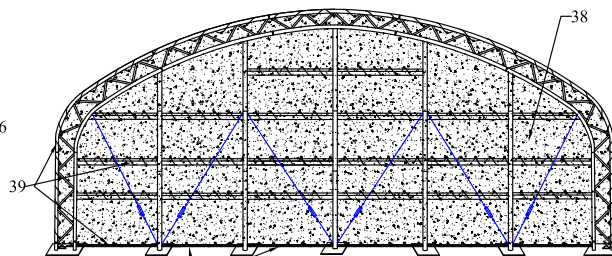

Installation of Back Panel Cover

## 20. Mechanical Door Installation Steps.

- Install main door pulleys (left and right) over the door on each side of the door beam (#43).
- Mount the winch mechanism to the front panel lower beam (#16C).
- Slide the bottom door dropping tube (#23, 23A) into the bottom horizontal fabric pocket on the door cover (#37). Then slide the six remaining door dropping tubes (#22, 22A) into the remaining horizontal fabric pockets in the door cover, and use the M5x10 self-tapping screws (#31A) to secure the door cover to the dropping tube.
- From the bottom of the door tracks, gently raise and slide one door dropping tube (#22,22A) into the tracks. Then feed the other remaining door dropping tubes (#22,22A, 23, 23A) into the door tracks.
- Install the steel wire that leads the door winching assembly to the bottom of the door dropping tubes. The winch assembly has a long and a short steel cable secured to it. Feed the end of the shorter of the two cables through the lower roller of the double pulley at the top of the door assembly track closest to the winch assembly, and then down through the holes in the bottom door dropping tube (#23, 23A) on the left hand side of door (from the inside). When the steel cable goes down through the hole in the bottom dropping tube (#23, 23A), tie a knot in the steel wire so that it cannot pass back through the hole.
- For the longer winch assembly route, lead the end of the longer steel cable through the upper roller of the double pulley on near the door track and then through the single roller on the door track farthest from the winch assembly then down through the bottom door dropping tube (#23, 23A). When the steel cable goes down through the hole in the bottom door dropping tube (#23, 23A), tie a knot in the steel cable. The door can now be opened or closed by operating the winch assembly. Raise and lower the door several times to be certain door tubes are not binding on the track. Lubricate if necessary.

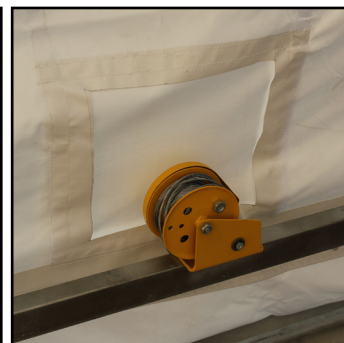

# INSTALLATION INSTRUCTIONS

## Front Mechanical Door Installation:

Door Dimensions: W15'1" (4.6m) x H17'1" (5.2)

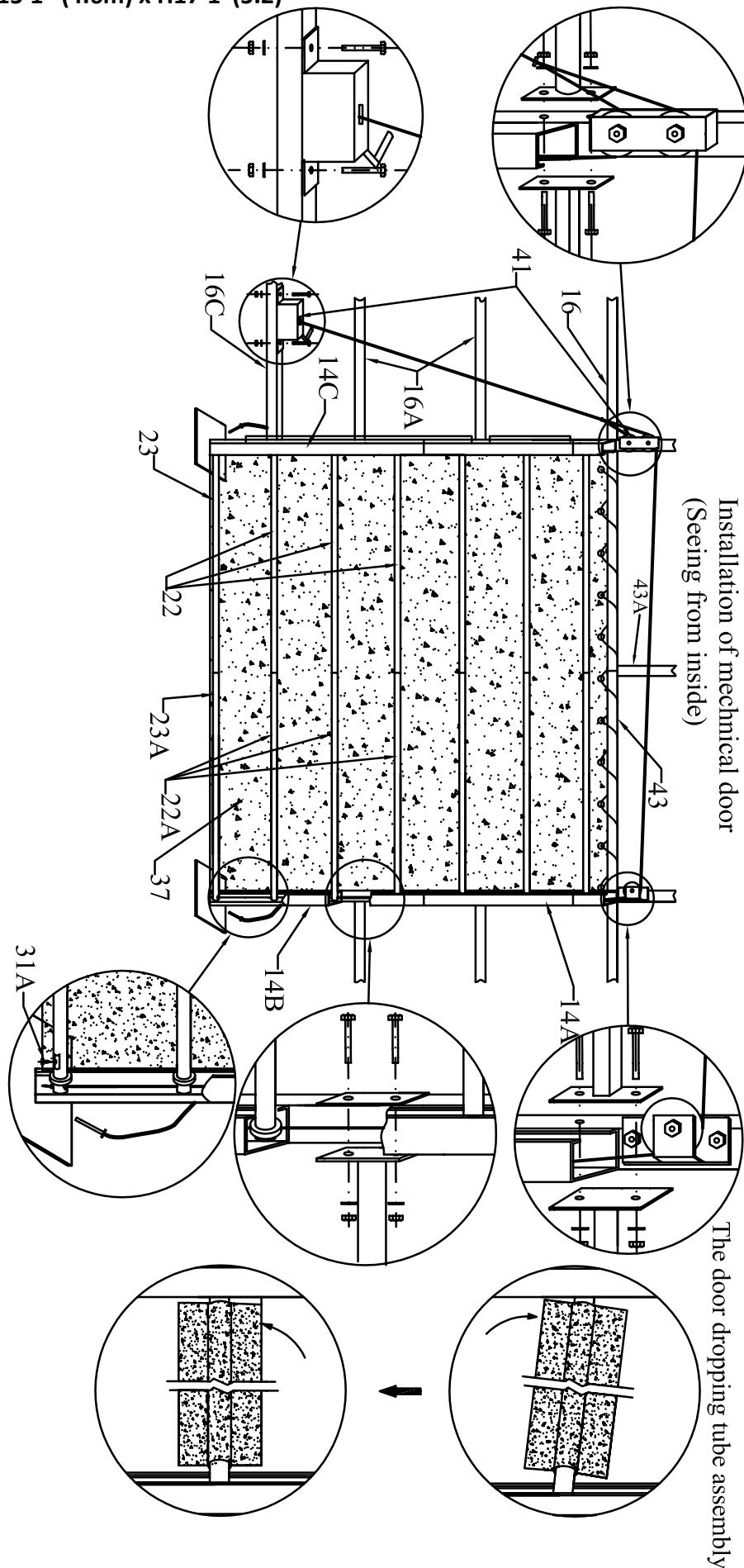

SAFETY

INSTALLATION

MAINTENANCE

CONTACTS

## FLAME RESISTANCE

Celina fabrics are inherently flame resistant. Open flames should never be used under any tent, canopy, structure, or shelter. Fabrics meet or exceed one or more of the following flammability specifications:

|          |                |             |
|----------|----------------|-------------|
| NFPA-701 | CPAI-84        | ASTM D 6413 |
| BS 5438  | BS 7837 (1996) | DIN 4102-B1 |

## TENT CARE

For maximum life of Celina fabrics, Celina recommends regular cleaning with the use of a soft brush with neutral soaps or cleaners, such as Celina Cleaning Products, Ivory dish soap, or warm water. Thorough rinsing and drying is required before storing the fabric.

### Things that will cause premature degradation and may reduce life expectancy of a tent:

- Improper handling during installation/dismantling on rough surfaces will create pinholes and abrasions. ALWAYS USE A DROP CLOTH/GROUND CLOTH DURING INSTALLATION AND DISMANTLING.
- Walking on the fabric during installation/dismantling will create pinholes and abrasions.
- Extended use of the tent without cleaning
- Accumulation of dirt on the vinyl surface will promote the growth of mold and mildew and premature wear.
- Storage of vinyl that has not been dried thoroughly. Even a slightly damp product can promote the growth of mildew when folded and stored. Mold and mildew may require harsh cleaners to remove, which may cause premature wear. The best solution is to take every precaution to keep mold and mildew from growing in the first place. NEVER STORE A TENT, CANOPY, STRUCTURE, OR SHELTER IN A WET OR DAMP CONDITION.
- Harsh detergents and cleaners, which contain a solvent or bleach. The longer the exposure of PVC vinyl to these products, the more it will reduce the life of the PVC vinyl.
- High-abrasive cleaners, including wire brushes, power washers and/or commercial washing machines will result in premature wear and deterioration of tent fabrics.
- Wind whip – Loosely tensioned fabric that whips in the wind will damage over time.

### Vinyl Repair

Celina's repair products provide an easy solution to tears, punctures, or holes. Repair kits and tools are available online at [www.GetTent.com](http://www.GetTent.com) or by contacting Celina.

## PRODUCT WARRANTY

Celina Tent Inc. warrants that this product will be free from defects in material and workmanship for a period of one (1) year following the date of purchase. Defects are limited to any defect which is a result of the manufacturing process. Excluded are holes, punctures, or other damages which can be caused during normal installation of a tent whenever proper procedures are not followed. Celina at its option will repair or replace this product or any component of product found to be defective during this warranty period. This warranty is valid for the original purchaser only, and is not transferable. This warranty does not cover normal wear or damage resulting from negligent use or misuse of the product, use contrary to instructions, repairs or alterations by anyone other than Celina, or forces of nature. Celina Tent is not responsible for methods that installers may choose to erect and secure the tent to the ground. Celina's responsibility is limited to the manufacture of the tent parts and materials.

This warranty is in lieu of all other warranties, and there are no warranties, expressed or implied, including warranties of merchantability of fitness for a particular purpose, which extend beyond the description on the face hereof. Celina Tent Inc. shall not be liable for any incidental or consequential damages. Some jurisdictions do not allow the exclusion of implied warranties or the imitation on incidental or consequential damages, so the above exclusions and limitations may not apply to you.

# CALL BEFORE YOU DIG OR STAKE

| STATE         | CENTER                                  | PHONE        |
|---------------|---|--------------|
| Alabama       | Alabama Line Location                   | 800/292-8525 |
| Alaska        | Locate Call Center of Alaska            | 800/478-3121 |
| Arizona       | Arizona Blue Stake                      | 800/782-5348 |
| Arkansas      | Arkansas One Call System                | 800/482-8998 |
| California    | Underground Service Alert               | 800/227-2600 |
| Colorado      | Utility Notification Center of Colorado | 800/922-1987 |
| Connecticut   | Call Before You Dig                     | 800/922-4455 |
| Delaware      | Miss Utility of Delaware                | 800/282-8555 |
| Florida       | Call Sunshine                           | 800/432-4770 |
| Georgia       | Utilities Protection Center             | 800/282-7411 |
| Hawaii        | Underground Service Alert North         | 800/227-2600 |
|               | Underground Service Alert South         | 800/227-2600 |
| Idaho         | Palouse Empire Underground              | 800/822-1974 |
|               | Utilities Underground Location Center   | 800/424-5555 |
|               | Dig Line                                | 800/342-1585 |
|               | One Call Concepts - Idaho               | 800/626-4950 |
|               | Shoshone County One Call                | 800/398-3285 |
| Illinois      | Chicago Utility Alert Network           | 800/892-0123 |
| Indiana       | Indiana Underground Plant Protection    | 800/382-5544 |
| Iowa          | Underground Plant Location Service      | 800/292-8989 |
| Kansas        | Kansas One-Call Center                  | 800/344-7233 |
| Kentucky      | Kentucky Underground Protection         | 800/752-6007 |
| Louisiana     | Louisiana One Call System               | 800/272-3020 |
| Maine         | Dig Safe - Maine                        | 888/344-7233 |
| Maryland      | Miss Utility                            | 800/257-7777 |
|               | Miss Utility of DESMARVA                | 800/282-8555 |
| Massachusetts | Dig Safe-Massachusetts                  | 888/344-7233 |
| Michigan      | Miss Dig System                         | 800/482-7171 |
| Minnesota     | Gopher State One Call                   | 800/252-1166 |
| Mississippi   | Mississippi One Call System             | 800/227-6477 |
| Missouri      | Missouri One Call System                | 800/344-7483 |
| Montana       | Utilities Underground Location Center   | 800/424-5555 |
|               | Montana U-Dig                           | 800/551-8344 |
| Nebraska      | Diggers Hotline                         | 800/331-5666 |
| Nevada        | Underground Service Alert North         | 800/227-2600 |
| New Hampshire | Dig Safe-New Hampshire                  | 888/344-7233 |
| New Jersey    | Garden State Underground                | 800/272-1000 |
| New Mexico    | New Mexico One Call System              | 800/321-2537 |
|               | Las Cruces-Dona Ana Utility Council     | 888/526-0400 |

| STATE                | CENTER                               | PHONE        |
|----------------------|--------------------------------------|--------------|
| New York             | Dig Safely New York                  | 800/926-7962 |
|                      | New York City-Long Island One Call   | 800/272-4480 |
| North Carolina       | North Carolina One Call              | 800/634-4949 |
| North Dakota         | North Dakota One Call                | 800/795-0555 |
| Ohio                 | Ohio Utilities Protective Service    | 800/362-2764 |
|                      | Oil & Gas Producers Underground      | 800/925-2988 |
| Oklahoma             | Call Okie                            | 800/522-6543 |
| Oregon               | Oregon Utilities Notification Center | 800/332-2344 |
| Pennsylvania         | Pennsylvania One Call System         | 800/242-1776 |
| Rhode Island         | Dig Safe-Rhode Island                | 888/344-7233 |
| South Carolina       | Palmetto Utility Protection Service  | 800/922-0983 |
| South Dakota         | South Dakota One Call                | 800/781-7474 |
| Tennessee            | Tennessee One-Call System            | 800/351-1111 |
| Texas                | Texas One Call System                | 800/245-4545 |
|                      | Texas Excavation Safety System       | 800/344-8377 |
|                      | Lone Star Notification System        | 800/669-8344 |
| Utah                 | Blue Stakes Location Center          | 800/622-4111 |
| Vermont              | Dig Safe - Vermont                   | 888/344-7233 |
| Virginia             | Miss Utility of Virginia             | 800/552-7001 |
|                      | Miss Utility                         | 800/257-7777 |
| Washington           | Miss Utility of DELMARVA             | 800/441-8355 |
|                      | Notification Center                  | 800/424-5555 |
|                      | Utilities Council of Cowlitz County  | 360/425-2506 |
|                      | Upper Yakima City Underground        | 800/553-4344 |
|                      | Inland Empire Utility Coordinating   | 509/456-8000 |
| West Virginia        | Miss Utility of West Virginia        | 800/245-4848 |
| Wisconsin            | Diggers Hotline                      | 800/242-8511 |
| Wyoming              | Wyoming One Call                     | 800/348-1030 |
|                      | Call Before you Dig Wyoming          | 800/849-2476 |
| District of Columbia | Miss Utility                         | 800/257-7777 |
| Canada               | Alberta One Call                     | 800/242-3447 |
|                      | Ontario                              | 800/400-2255 |
|                      | Info-Excavation (Quebec)             | 800/663-9228 |
|                      | BC One Call                          | 800/474-6886 |
|                      | Manitoba - Winnipeg                  | 240/480-1212 |
|                      | Manitoba & Saskatchewan Safe         | 800/827-5094 |

SAFETY

INSTALLATION

MAINTENANCE

## SUPPORT

**For technical questions or replacement parts, please contact:**

Celina Tent, Inc. / GetTent.com  
 5373 State Route 29  
 Celina, Ohio 45822-9210 USA

**Telephone:** 419-586-3610

**Fax:** 419-584-0949

**Website:** www.GetTent.com

**Email:** support@celinatent.com

**YouTube:** <http://www.youtube.com/user/celinatent>

**Facebook:** <http://www.facebook.com/celinatent>

**Google +:** <http://goo.gl/qvVdv>

**Twitter:** <http://twitter.com/celinatent>

**LinkedIn:** <http://www.linkedin.com/company/celina-tent-fabric-structures>

CONTACTS